

Maserati Block Construction Detail

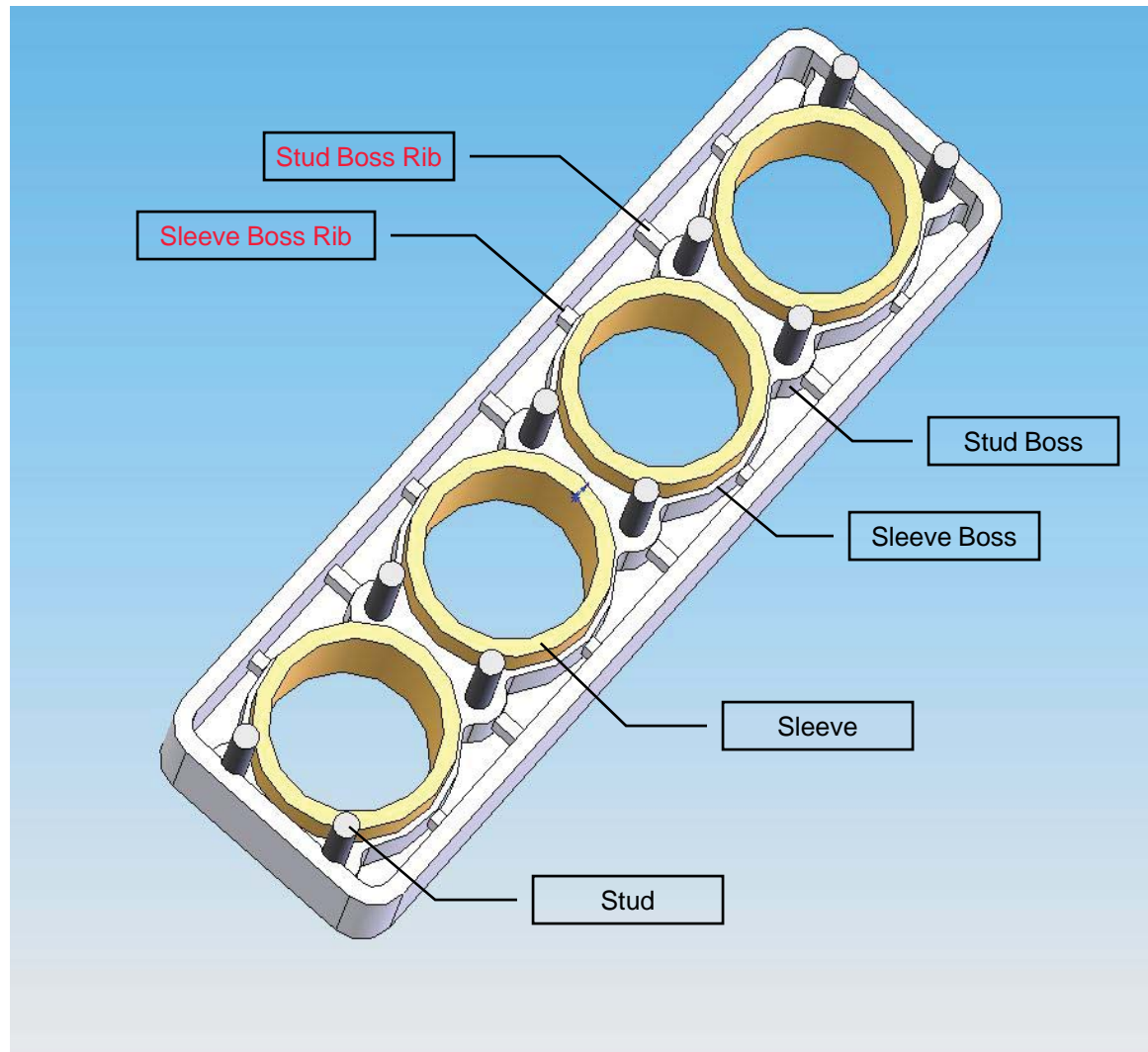

A simplified model of one cylinder bank of the Maserati V8 Block is shown above. The block is of open deck construction with cylinder sleeves and head studs cantilevered from the Aluminium block. All Sleeve Boss Ribs (8 per bank, 16 total) are cracked.

Maserati Typical Cracks

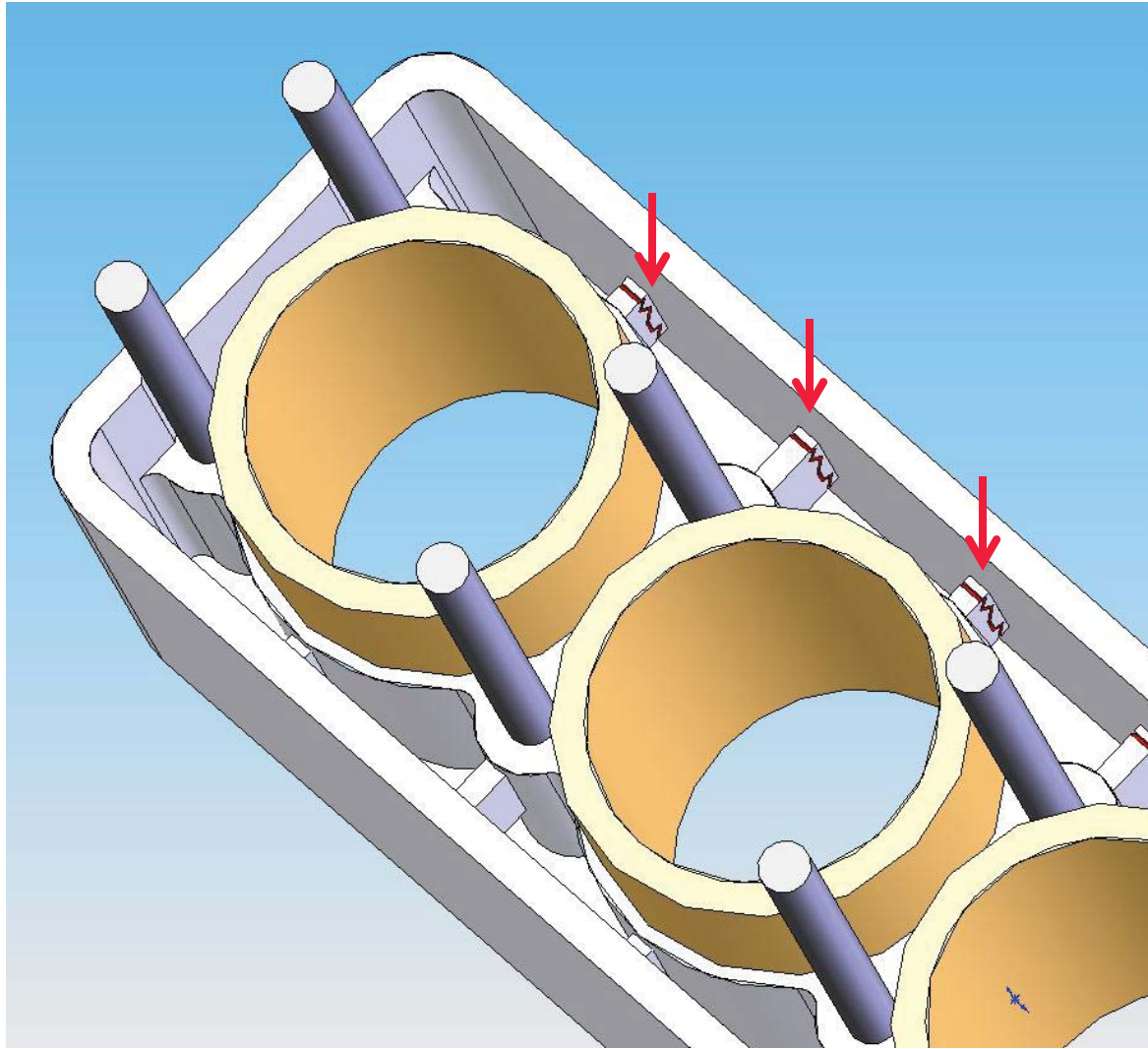

Typical cracks are shown, marked with red arrows. The center crack is in a Stud Boss Rib. The other two are in Sleeve Boss Ribs.

Pin Repair – Top View

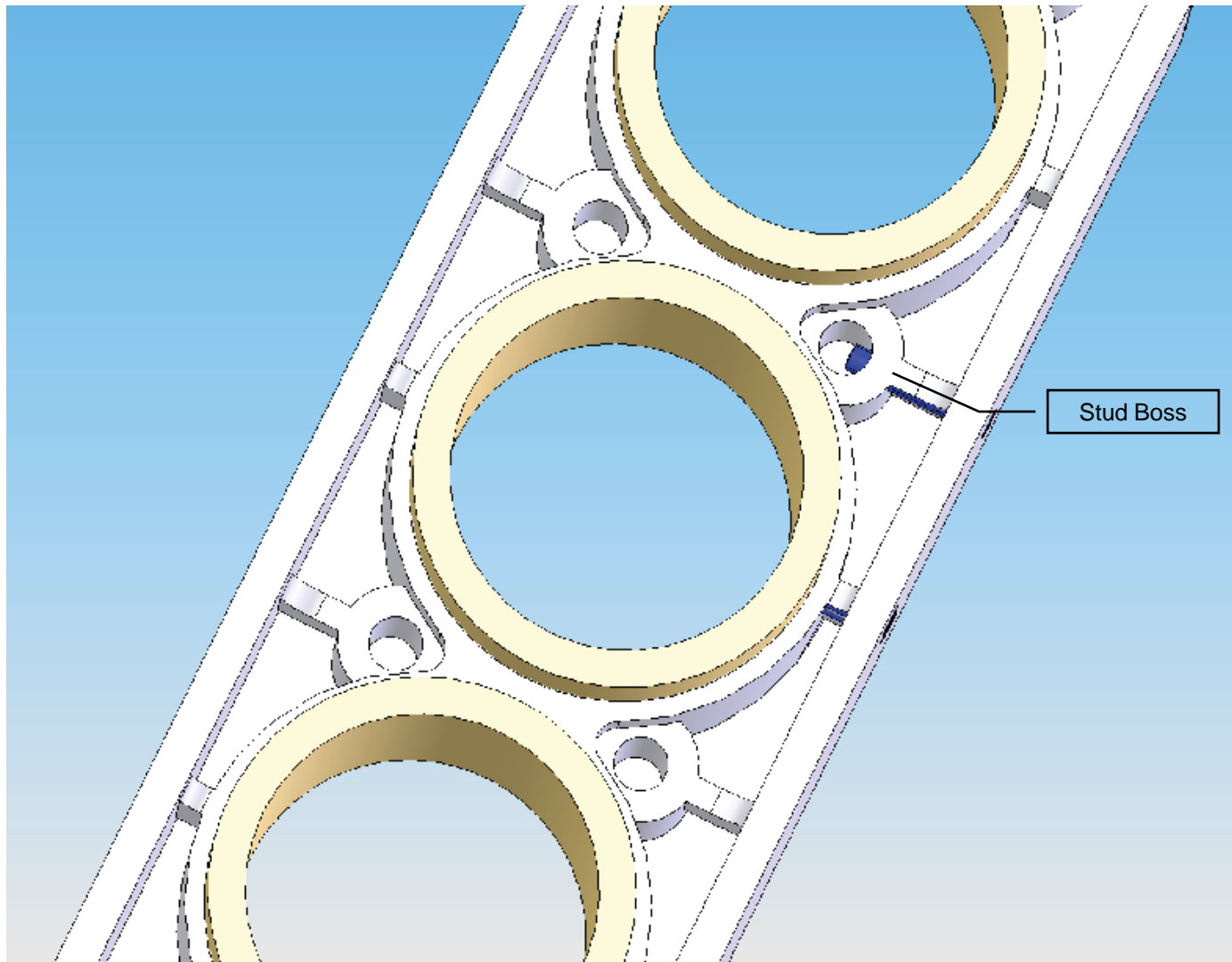

For maximum strength, pins in the stud boss ribs protrude into the stud thread area. They will be trimmed later.

Pin Repair – Top View – Pins Visible

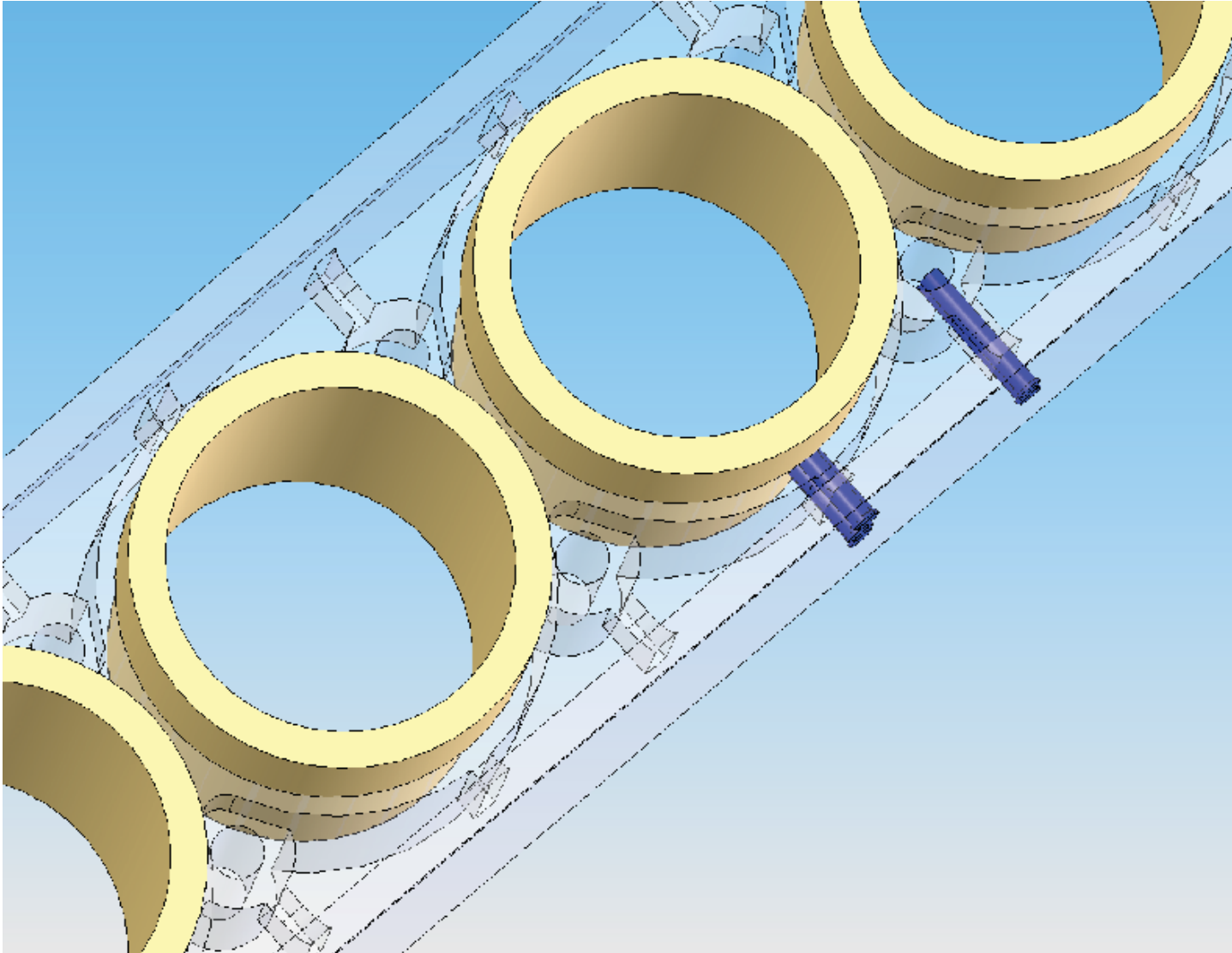

Top view with pins shown.

Precision Pin Repair – Pin Location

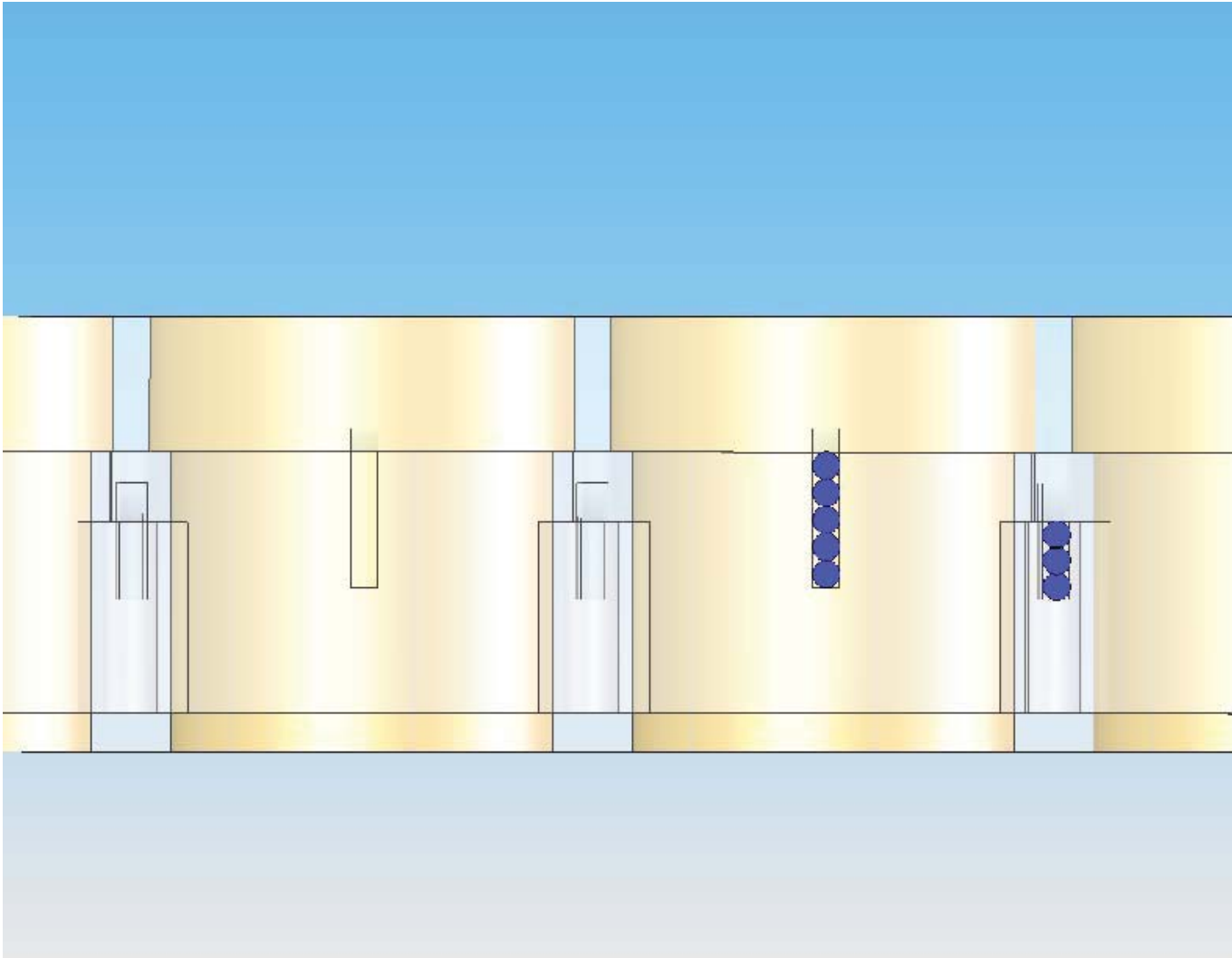

Inspection and modeling of the block results in precision placement of pins.

Precision Pin – Section View

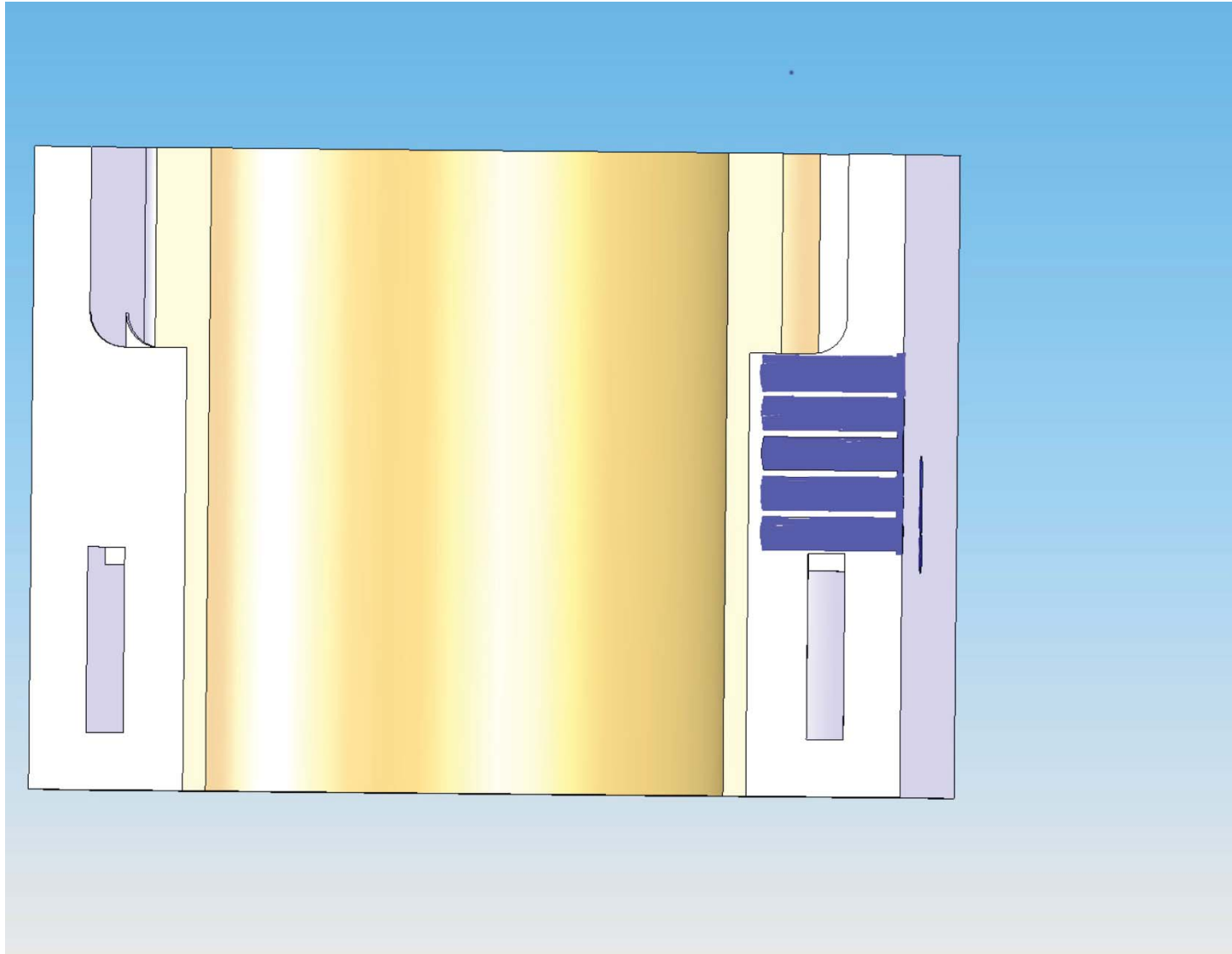

Section view of pins in sleeve boss rib. Note precision placement and that they stop short of the cast iron sleeve.

Precision Pin - Final

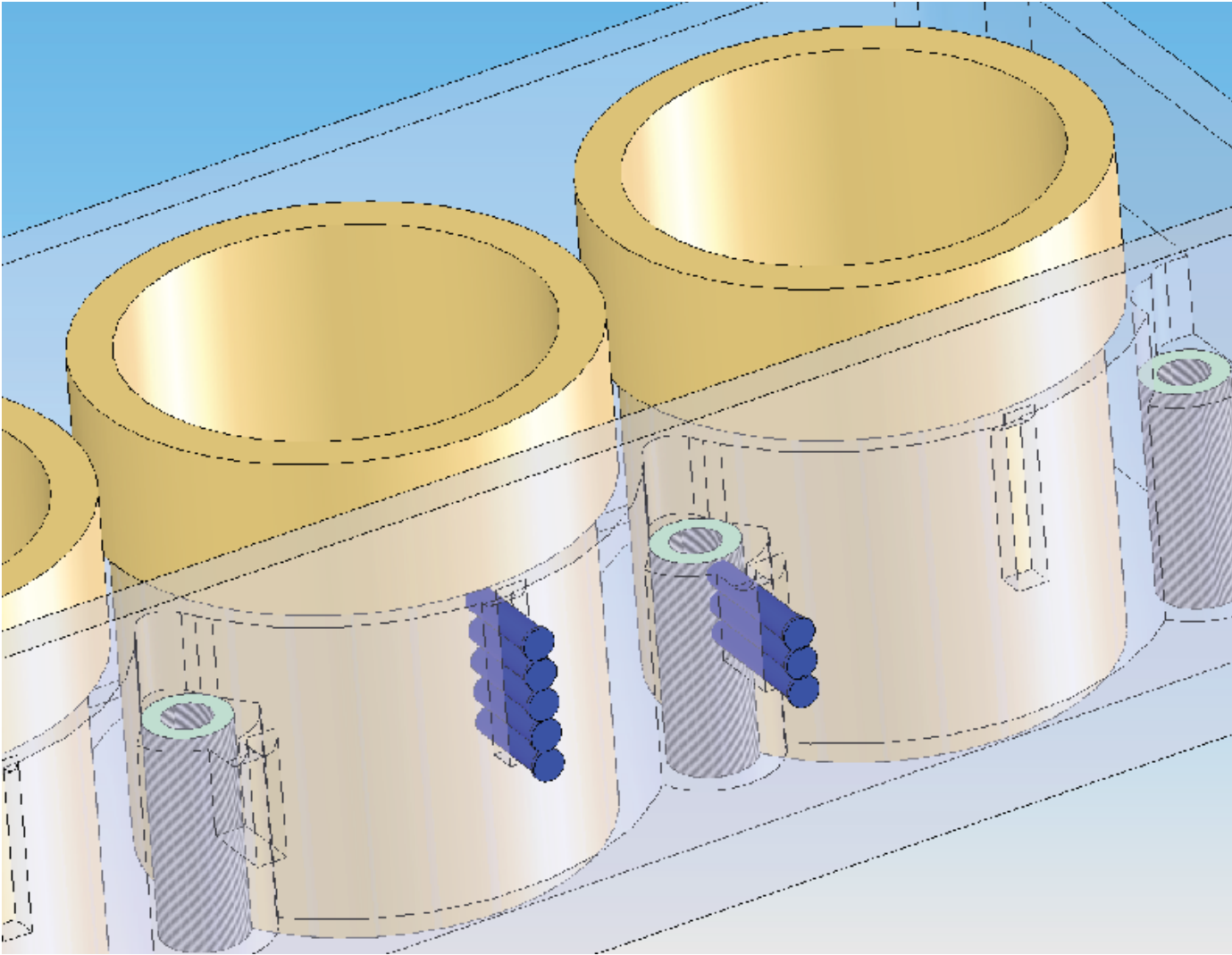

Completed repair showing pins and threaded inserts.